

DRAGZILLA

2024

SUPPLEMENTARY REGULATIONS 2W & 4W

ORGANISED BY



OFFICIAL WEBSITE: gearheadmotorsportsfoundation.org

EMAIL : motorsportsgearhead@gmail.com

Name of the event	DRAGZILLA VOL. 1
Start Date of the event	12/09/2024
End Date of the event	14/09/2024
Status of the event	Open
Category	2W or 4W
Name of the Organizer	GEARHEAD MOTORSPORTS FOUNDATION
Office Address	H.No- 21, GMCH LINK ROAD, DISPUR, GUWAHATI, ASSAM - 781005
Phone	+91 73996 – 68414 / 88110-58485
Email	motorsportsgearhead@gmail.com
Website	gearheadmotorsportsfoundation.org

WARNING

MOTORSPORT CAN BE DANGEROUS. DESPITE ORGANIZERS TAKING ALL POSSIBLE PRECAUTIONS UNAVOIDABLE ACCIDENTS MAY HAPPEN. YOU ARE PRESENT HERE AT YOUR OWN RISK.

1. INTRODUCTION	Error! Bookmark not defined.
2. ORGANIZATION	Error! Bookmark not defined.
3. PROGRAMME	Error! Bookmark not defined.
4. ENTRIES	Error! Bookmark not defined.
5. INSURANCE	Error! Bookmark not defined.
6. ADVERTISEMENT AND IDENTIFICATION	Error! Bookmark not defined.
7. ADMINISTRATIVE CHECKS	Error! Bookmark not defined.
8. PRE-EVENT SCRUTINEERING, SEALING AND MARKING	Error! Bookmark not defined.
9. IDENTIFICATION OF OFFICIALS	Error! Bookmark not defined.
11. PRIZES	Error! Bookmark not defined.
12. PROTEST & APPEAL	Error! Bookmark not defined.
13. RUNNING OF THE EVENT	Error! Bookmark not defined.
14. SAFETY REQUIREMENTS	Error! Bookmark not defined.
NAMES AND PHOTOGRAPHS OF CRO'S	Error! Bookmark not defined.

1. Introduction

1.1 DRAGZILLA VOL.1 will run in compliance with the 2024 International Sporting Code of the Federation Internationale de l'Automobile (FIA), 2024 FMSCI General Prescriptions for Drag Racing, the relevant Drag Technical Regulations and these Supplementary Regulations (SRs). The Federation of Motor Sports Clubs of India (FMSCI) is the National Sporting Authority (ASN) of FIA in India. Modifications, amendments and / or changes to these SRs will be announced only by numbered and dated bulletins, issued by the organizers, approved by the FMSCI or Stewards.

1.2 Acquaintance with and submission to Rules Every person, or group of persons, organizing a competition or taking part therein - Shall be deemed to be acquainted with all the relevant rules and regulations of the FMSCI - All competitors must sign the indemnity and declaration form, which are enclosed with the Entry Form - These are conditions precedent attached to the submission of entries and taking part in an event and all competitors participating shall be bound by them and also the rules and regulations hereinafter set out or amendments made thereto. - Shall undertake to submit themselves without reserve to the above and to the decision and consequences resulting therefrom.

2. Organization

2.1 FMSCI Permit No./s: TBA

2.2 Organizers name, address and contact details

GEARHEAD MOTORSPORTS FOUNDATION
H.No- 21, GMCH LINK ROAD, DISPUR, GUWAHATI, ASSAM – 781005
+91 73996 – 68414 / 88110-58485
motorsportsgearhead@gmail.com
gearheadmotorsportsfoundation.org

2.3 Managing Committee

2.4 Organizing Committee

2.5 FMSCI Officials

Chief Steward	
Steward	
Steward	
Chief Scrutineer	

2.6 Senior Officials

Clerk of the Course	
Assistant Clerk of the Course	VINEET RATHI
Secretary of the Meet	
Chief Safety Officer	
Chief Medical Officer	ALOTED BY THE HOSPITAL
Chief Time Keeper	
Competitors Relations Officer	
Media Relations Officer	
Results Co-ordinator	
PADDOCK IN-CHARGE	
ASST PADDOCK IN-CHARGE	
ASST PADDOCK IN-CHARGE	
ASST.SCRUTINEER 2W / 4W	
PARC FERME IN-CHARGE	

ASST. PARC FERME IN-CHARGE	
LEFT / RIGHT LANE MARSHALL	

2.7 Location of HQ

From :

DAY	DD/MM/YYYY	TIME (HRS)	VENUE
THURSDAY	13/06/2024	10:00	173, MEGZINE, MAHAPURUSH MADHABDEV ROAD, GUWAHATI ASSAM – 781171

To :

DAY	DD/MM/YYYY	TIME (HRS)	VENUE
MONDAY	09/09/2024	19:00	173, MEGZINE, MAHAPURUSH MADHABDEV ROAD, GUWAHATI ASSAM – 781171

From :

DAY	DD/MM/YYYY	TIME (HRS)	VENUE
THURSDAY	12/09/2024	10:00	BALJEK AIRPORT, NH-51, JENGJAL, MEGHALAYA 794109 https://maps.app.goo.gl/WwNFYu7TZu8MtLV18

TO :

DAY	DD/MM/YYYY	TIME (HRS)	VENUE
SATURDAY	14/09/2024	20:00	BALJEK AIRPORT, NH-51, JENGJAL, MEGHALAYA 794109 https://maps.app.goo.gl/WwNFYu7TZu8MtLV18

3. Programme

12TH SEPTEMBER, 2024 (THURSDAY)	
TIME	DETAILS
08:00 hrs	DOCUMENTS VERIFICATION, ISSUING ID & COMP.NO'S ETC
09:00 hrs	SCRUTINY OPEN FOR ALL 2W - & 4W
11:00 hrs	PAID PRACTICE
13:00 hrs	LUNCH BREAK
14:00 hrs	FIRST STEWARDS MEETING
15:30 hrs	STEWARDS TRACK INSPECTION
16:00 hrs	TRACK CLOSED
17:00 hrs	SCRUTINY CLOSE

13TH SEPTEMBER 2024 (FRIDAY)	
TIME	DETAILS
08:00 to 12:00 hrs	SCRUTINY OPEN FOR ALL 2W & 4W (FOR OUTSTATION PARTICIPANTS ONLY) NOT FOR CLASSES RUNNING ON FRIDAY
08:00 hrs	MANDATORY RIDER'S / DRIVER'S BRIEFING
08:30 hrs	OFFICIAL PRACTICE OPEN
10:30 hrs	OFFICIAL PRACTICE CLOSE
11:00 hrs	START OF DRAG – CLASSES 2W/4W (CODES TBA)
14:00 hrs	LUNCH BREAK
17:00 hrs	PRIZE DISTRIBUTION (DAY 1)
18:00 hrs	TRACK CLOSED

14TH SEPTEMBER, 2024 (SATURDAY)	
TIME	DETAILS
08:00 hrs	MANDATORY RIDER'S / DRIVER'S BRIEFING (ONLINE/OFFLINE)
09:00 hrs	OFFICIAL PRACTICE OPEN
10:30 hrs	OFFICIAL PRACTICE CLOSE
11:00 hrs	START OF DRAG – CLASSES 2W/4W (CODES TBA)
14:00 hrs	LUNCH BREAK
17:00 hrs	PRIZE DISTRIBUTION (DAY 2)
18:00 hrs	TRACK CLOSED

4. Entries

4.1 Opening and Closing Dates Entries open with the publication of these Supplementary Regulations

Closing date of all entries: 10/09/2024 @ 18:00 hrs

4.2 Entry Procedure

Those wishing to take part in the event must send the enclosed entry form duly completed to the permanent secretariat address given in Art.2.2 prior to the closing date as mentioned in Art.4.1

4.3 Maximum number of Entries

The maximum number of entries accepted would be no more than 600. If more entries are than these are received, then the organizers reserve the right to decide which entries would be accepted.

4.4 Category, Groups & Classes & Entry Fees

FMSCI APPROVED CLASSES 2 WHEELERS

2 Wheelers: Scooters: Super Sport – Class A	
CLASS	ENTRY FEES
Upto 80 cc – A1	1000+ 18% GST
81 cc – 110 cc – A2	1000 + 18% GST
111 cc -160 cc – A3	1000 + 18% GST
161 cc and above – A4	1000 + 18% GST

2 Wheelers: 2 Stroke: Super Sport – Class B	
CLASS	ENTRY FEES
Upto 130 cc – B1	1000+ 18% GST
131 cc – 165 cc – B2	1500+ 18% GST
350 cc and above – B3	1500+ 18% GST

2 Wheelers: 4 Stroke: Super Sport – Class C	
CLASS	ENTRY FEES
Upto 165 cc - C1	1500+ 18% GST
166 cc – 225 cc – C2	1500 + 18% GST
226 cc – 360 cc – C3	1500 + 18% GST
361 cc – 550 cc – C4	1500 + 18% GST
551 cc – 850 cc – C5	2000+ 18% GST
Single / Twin 551 cc – 750 cc – C6	2000+ 18% GST
Single / Twin 751 cc and above – C7	2000+ 18% GST

2 Wheelers: 4 Stroke: Super Sport – Class D	
CLASS	ENTRY FEES
851 cc – 1050 cc -D1	3000 + 18% GST

1051 cc –1650 cc - D2	3000 + 18% GST
1651 cc and above – D3	3000 + 18% GST

2 Wheelers: Unrestricted – Class E	
CLASS	ENTRY FEES
Upto 395 cc – E1	3500 + 18 GST
396 cc to 550 cc – E2	3500 + 18% GST
551 cc and above – E3	3500 + 18% GST

2 Wheelers: Class EV OPEN (Electric 2 wheelers only. IC engine vehicles or hybrids not permitted)	
EV 1 - SCOOTER	2000+ 18 % GST
EV 2 - BIKE	2000+ 18 % GST

PROMOTER CLASSES

2 Wheelers:Class F	
CLASS	ENTRY FEES
WHEELIE CLASS INDIAN / SUPER BIKE F1	3000 + 18% GST
NAKED OPEN F2	3000 + 18 % GST
4 STROKE OPEN UPTO 500 CC F3	3000 + 18 % GST
TBA	

2 Wheelers: 4 Stroke: Super Stock INDIAN – Class G	
CLASS	ENTRY FEES
Upto 165 cc - S1	WOMEN IN MOTORSPORTS (WIM) 2000+ 18% GST
166 cc – 225 cc – S2	
226 cc – 360 cc – S3	
361 cc – 550 cc – S4	
551 cc – 850 cc – S5	
Single / Twin 551 cc – 750 cc – S6	
Single / Twin 751 cc and above – S7	

FMSCI APPROVED CLASSES 4 WHEELERS

4 Wheelers : Street Stock Petrol: Class I (Two Wheel Drive)	
CLASS	ENTRY FEES
Upto 1150 cc – I1	2000 + 18 % GST
1151 cc – 1450 cc – I2	2000 + 18 % GST
1451 cc – 1650 cc – I3	2000 + 18 % GST
1651 cc – 2050 cc – I4	2000 + 18 % GST
2051 cc – 2550 cc – I5	3000+ 18 % GST
2551 cc – 3060 cc – I6	3000 + 18 % GST
3061 cc – 4000 cc – I7	4000 + 18 % GST
4001 cc – 5100 cc – I8	4000 + 18 % GST

5101cc and above – I9	4000 + 18 % GST
-----------------------	-----------------

4 Wheelers: Street Stock Diesel: Class J (Two wheel drive)	
CLASS	ENTRY FEES
Upto 1150 cc – J1	2000 + 18 % GST
1151 cc – 1450 cc – J2	2000 + 18 % GST
1451 cc – 1650 cc – J3	2000 + 18 % GST
1651 cc – 2050 cc – J4	2000 + 18 % GST
2051 cc – 2550 cc – J5	3000 + 18 % GST
2551 cc – 3060 cc – J6	3000 + 18 % GST
3061 cc – 4000 cc – J7	3000 + 18 % GST
4001 cc – 5100 cc – J8	3000 + 18 % GST
5101cc and above – J9	3000 + 18 % GST

4 Wheelers: Street Stock Petrol: Class Ia (Two Wheel Drive+ Four wheel drive)	
CLASS	ENTRY FEES
Upto 1150 cc – I1a	2500 + 18% GST
1151 cc – 1450 cc – I2a	2500 + 18% GST
1451 cc – 1650 cc – I3a	2500 + 18% GST
1651 cc – 2050 cc – I4a	3000 + 18% GST
2051 cc – 2550 cc – I5a	3000 + 18% GST
2551 cc – 3060 cc – I6a	3500 + 18 % GST
3061 cc – 4000 cc – I7a	3500 + 18 % GST
4001 cc – 5100 cc – I8a	3500 + 18 % GST
5101cc and above – I9a	3500 + 18 % GST

4 Wheelers: Street Stock Diesel: Class J (Two wheel drive+ Four wheel drive)	
CLASS	ENTRY FEES
Upto 1150 cc – J1a	2500 + 18 % GST
1151 cc – 1450 cc – J2a	2500 + 18 % GST
1451 cc – 1650 cc – J3a	2500 + 18 % GST
1651 cc – 2050 cc – J4a	2500 + 18 % GST
2051 cc – 2550 cc – J5a	3500 + 18 % GST
2551 cc – 3060 cc – J6a	3500 + 18 % GST
3061 cc – 4000 cc – J7a	3500 + 18 % GST
4001 cc – 5100 cc – J8a	3500 + 18 % GST
5101cc and above – J9a	3500 + 18 % GST

4 Wheelers: Pro Stock Petrol: Class K	
CLASS	ENTRY FEES
Upto 1150 cc – K1	2500 + 18 % GST
1151 cc – 1450 cc – K2	2500 + 18 % GST
1451 cc – 1650 cc – K3	2500 + 18 % GST
1651 cc – 2050 cc – K4	2500 + 18 % GST

2051 cc – 2550 cc – K5	2500 + 18 % GST
2551 cc – 3060 cc – K6	3500 + 18 % GST
3061 cc – 4000 cc – K7	3500 + 18 % GST
3061 cc – 4000 cc – K7a	3500 + 18 % GST
4001 cc – 5100 cc – K8	3500 + 18 % GST
5101cc and above – K9	3500 + 18 % GST

4 Wheelers: Pro Stock Diesel: Class L	
CLASS	ENTRY FEES
Upto 1150 cc – L1	2500 + 18 % GST
1151 cc – 1450 cc – L2	2500 + 18 % GST
1451 cc – 1650 cc – L3	2500 + 18 % GST
1651 cc – 2050 cc – L4	2500 + 18 % GST
2051 cc – 2550 cc – L5	3500 + 18 % GST
2551 cc – 3060 cc – L6	3500 + 18 % GST
3061 cc – 4000 cc – L7	4000 + 18 % GST
4001 cc – 5100 cc – L8	4000 + 18 % GST
5101cc and above – L9	4000 + 18 % GST

4 Wheelers:Indian Open: Class M	
CLASS	ENTRY FEES
Upto 2750 cc – M1	4000 + 18 % GST
Upto 1500 cc – M2	4000+ 18 % GST
Unlimited – M3	5000 + 18 % GST

4 Wheelers: Unrestricted Class: Class N	
CLASS	ENTRY FEES
UNRESTRICTED N1	5000+ 18 % SGT

4 Wheelers: ET Novice: Class O (Two wheel drive)		
CLASS	MINIMUM ELAPSED TIME	ENTRY FEES
Upto 1150 cc – O1	18.25 secs	3000 + 18% GST
1151 cc – 1450 cc – O2	17.75 secs	3000 + 18% GST
1451 cc – 1650 cc – O3	17.00 secs	3000 + 18% GST
1651 cc – 2050 cc – O4	16.00 secs	3000 + 18% GST
2051 cc – 2550 cc – O5	15.50 secs	3000 + 18% GST
2551 cc – 3060 cc – O6	14.00 secs	3500 + 18% GST
3061 cc – 4000 cc – O7	13.25 secs	3500 + 18% GST

4 Wheelers: ET Professional: Class P (two wheel drive+ four wheel drive + Imported cars)		
CLASS	MINIMUM ELAPSED TIME	ENTRY FEES
Upto 2550 cc – P1	13.50 secs	3500 + 18% GST
2551 cc – 3060 cc – P2	13.00 secs	3500 + 18% GST
3061 cc – 4000 cc – P3	12.40 secs	3500 + 18% GST
4001 cc – 5100 cc – P4	11.50 secs	4000 + 18% GST
5101 cc and above – P5	9.60 secs	4000 + 18% GST

4 Wheelers: EV Open: Class Q	
	3600 + 18% GST

PROMOTER CLASSES

4 Wheelers:	
CLASS	ENTRY FEES
VW VS SKODA OPEN R1	2500 + 18 % GST
TURBO OPEN R2	7500 + 18 % GST
<u>TBA</u>	
<u>TBA</u>	

Entry fees are inclusive of taxes applicable.

4.5 Payment

The entry fees can be either by demand draft in favour of DRAGZILLA payable at GUWAHATI or by cash or by wire transfer.

BANK NAME	<u>HDFC BANK</u>
BRANCH	<u>CHRISTIAN BASTI</u>
NATURE OF ACCOUNT	<u>CURRENT</u>
ACCOUNT NUMBER	<u>50200090024472</u>
IFSC Code	<u>HDFC0001474</u>

4.6 Refund

Entries fees will be refunded in full only

- To candidates whose entry has not been accepted
- In case of event not taking place The organizers may refund 50% of the entry fee to those competitors who, for reasons of force-majeure (duly accepted by the organizing committee) were unable to start in the event, only with the event being held and Competitor being able to not participate.

5. Insurance

Organizers holding a valid 2024 FMSCI Permit for an event are covered for
Organizers holding a valid 2024 FMSCI Permit for an event are covered for

Competitors: A maximum of 250 competitors with valid FMSCI Competition License participating in various events across the Country on a given day are covered for Personal Accident Insurance for Rs. 5 lakhs with Rs. 5 Lakhs medical expense extension per person.

Officials: A maximum of 100 officials officiating in various events across the Country on a given day are covered for Personal Accident Insurance for Rs.25 lakhs with Rs.1 lakh medical expense extension per person.

THESE INSURANCES ARE ISSUED BY NEW INDIA INSURANCE COMPANY LTD AND VALID DURING THE RUNNING OF THE EVENT ONLY. ORGANIZERS / COMPETITORS ARE ADVISED TO TAKE ANY

ADDITIONAL INSURANCES THEY MAY DEEM FIT. IF THEY HAVE MORE THAN 100 OFFICIALS & ALSO REQUIRE DOOR TO DOOR COVERAGE PLEASE CONTACT:

Third Party Liability Insurance (Minimum 50 lakhs) taken by the Organizers

Dates covered: 13th, 14th and 15th of September 2024

Amount: TBA

Company: TBA

6. Advertisement and Identification

6.1 It is compulsory to carry organizers advertisement on the competing vehicles.

6.2 Competitors are allowed to affix any kind of advertisements on their vehicle provided that

- Any instructions issued by the organisers are observed.
- It is authorized by the National laws and FMSCI regulations
- Advertising must not be of a political, obscene or insulting nature. It must be in good taste and not conflict with the vehicle's official numbers in any way
- It should not be placed as to prevent recognition by Officials or Marshals.
- The space designated in Appendix '4' of the General Prescription is left free of advertising other than that provided by the organisers.
- f It does not encroach upon the spaces reserved for number plates and windscreen strips,
- It does not interfere with the driver's vision through the windows.

7. Administrative checks

7.1 Documents Submission

Entrants should produce the following for inspection at the time of submitting the vehicle for pre-event scrutiny and administrative check on the date / time as mentioned in Art.3.

Competitors are required to bring:

- i) Special Drag Insurance cover valid for the dates of the event (Recommended)
- ii) Authority letter from owner of the vehicle if the driver / rider is not the owner of the vehicle used in the event
- iii) FMSCI Competition License for Driver (Minimum 4W Clubsport Drag Licence. Apply online from <http://licence.fmsci.co.in/>)
- iv) Entrant Licence / FMSCI Registration (if any)
- v) Pan Card copy of Competitor
- vi) 3 Passport size photographs Competitors are required to carry all the above documents throughout the event. All the documents shall be valid for the date of the event.

8. Pre-event Scrutineering, Sealing and Marking

8.1 Pre event Scrutiny Venue & Timings

Place : **BALJEK AIRPORT, TURA, Meghalaya**

8.2 Competitors Briefing Venue and timings

Place : **BALJEK AIRPORT, TURA, Meghalaya**

Date : REFER THE ARTICLE 3 OF THE SUPPLEMENTARY REGULATIONS

Time : REFER THE ARTICLE 3 OF THE SUPPLEMENTARY REGULATIONS

9. Identification of Officials

Safety Marshal	Orange
Safety Officer	Orange with white stripe and text
Post Chief	Blue with white stripe and text
Media	Green
Stage Commander	Red with text
Competitor Relations Officer	Red Jacket or Red Tabard
Medical	White
Radio	Yellow with blue mark
Scrutineer	Black

10. Prizes

1st , 2nd & 3rd Trophy + Certificate , Special Prizes & Tuner's Trophy for Fastest Times. THE ORGANISER RESERVES THE RIGHT INCREASE THE PRIZES OR PRIZE MONEY (IF ANY)

11. Protest & Appeal

11.1 LODGING A PROTEST OR APPEAL

All protests and / or appeals must be lodged in accordance with the stipulations of Articles 13,14 and 15 of the Code.

11.2 PROTEST FEES

11.2.1 For Closed, Closed Invitation and Open Events, the protest fees is ₹7,080/= (Rupees Seven Thousand Eighty Only) (₹6,000/= +₹1080 GST) .

For Challenge, Cups, Series, Trophy, League Events, the protest fees is ₹14,160/= (Rupees Fourteen Thousand One Hundred Sixty Only) - GST included

For National status upto International Events, the protest fees is ₹21,240/-/= (Rupees Twenty One Thousand Two Hundred Forty Only) - GST included (Refer to FMSCI Schedule of Fees on www.fmsci.co.in for details).

11.2.2 If a protest requires the dismantling and re-assembly of a clearly defined part of the bike/car any additional deposit must be specified in the Supplementary

Regulations– or will be specified by the Stewards upon a proposal of the FMSCI Technical Delegate / Chief Scrutineer.

11.2.3 If the protest is overruled or it is withdrawn after being brought, no part of the fee shall be returned. (Article 13.10.1 of FIA International Sporting Code)

11.2.4 If it is proved that the author of the protest has acted in bad faith, the FMSCI may inflict upon them one of the penalties laid down in the Code. (Article 13.10.3 of sporting code)

11.3 APPEALS

₹113,280/= (Rupees One Lakh Thirteen Thousand Two Hundred Eighty Only)
(₹96,000/= +₹17,280/= GST)

- Competitors may appeal against decisions, in accordance with the stipulations set out in Articles 15.1 of the Code.
- Competitors have the right to appeal against a sentence or other decisions pronounced on them by the Stewards of the meeting. They must, however under pain of forfeiture of their right to appeal, notify the Stewards of the Meeting in writing within one hour of the publication of the decision, of their intention to appeal.
- The right to bring an appeal expires 96 hours from the moment the stewards are notified of the intention to appeal on condition that the intention of appealing has been notified in writing to the stewards within one hour of the publication of the decision. These grounds of appeal may be brought by fax or by any other electronic means of communication with confirmation of receipt. Confirmation by a letter of the same date accompanied by the necessary fee is required. The FMSCI will give its decision within a maximum of 30 days.
- All parties concerned shall be given adequate notice of the hearing of any appeal. They shall be entitled to call witnesses, but their failure to attend the hearing shall not interrupt the course of the proceedings.
- The confirmation of an appeal to the FMSCI must be accompanied by a fee of ₹113,280/= (Rupees One Lakh Thirteen Thousand Two Hundred Eighty Only).
- This fee becomes due from the moment the appellant notifies the Steward of the intention of appealing, and remains payable even if the appellant does not follow up the declared intention to appeal.
- If the appeal is rejected or it is withdrawn after being brought, no part of the fee shall be returned.
- If judged partially founded, the fee may be returned in part, and in its entirety if the appeal is upheld.
- If it is proved that the author of the appeal has acted in bad faith, the FMSCI may inflict upon them one of the penalties laid down in the Code.

12. Running of the Event

Distance:402 metres 1/4 mile

Width of the track:100 feet

Maximum Number of runs per day including practice:200+125

13. Safety Requirements

Please refer General Prescriptions.

Names and photographs of CRO's

Will be present at :

- the Secretariat.
- the start of the scrutineering.
- Near the "PIT AREA".

Competitors Briefing , Pre event Scrutiny and Post event scrutiny

The competitors briefing will be held at a time and venue noted under point 8 above. All competitors MUST attend the briefing where an attendance register will be maintained. Non attendance will be reported to the stewards and shall entail a penalty of Rs2000/ and or disqualification.

Any vehicle taking part in the event must be presented by the competitor or his official representative to scrutineering at a time and venue noted under point 8 above. Competitors not adhering to the schedule will be charged a late scrutiny fee of Rs100/minute for a maximum of 15 minutes after which the competitor will be excluded. There will no refund of entry fees.

All competitors must present the prescribed safety gear (eg . Helmets , overalls, shoes , gloves, riding suit etc) to the scrutineer at the pre event scrutiny, and the vehicle must be presented with the competition number decals affixed.

All competing vehicles will remain in the Parc Ferme until officially released by the organiser. The top 3 or 4 competitors may be subjected to compulsory post event scrutiny. The FMSCI Technical delegate or Steward can at their discretion can dismantle and scrutinise any vehicle at any given time during the course of the event.

ADDITIONAL SUPPLEMENTARY REGULATIONS BY THE ORGANISER

WAIVERS SECTION

APPENDIX 1: COMPETITION NUMBERS & ADVERTISING

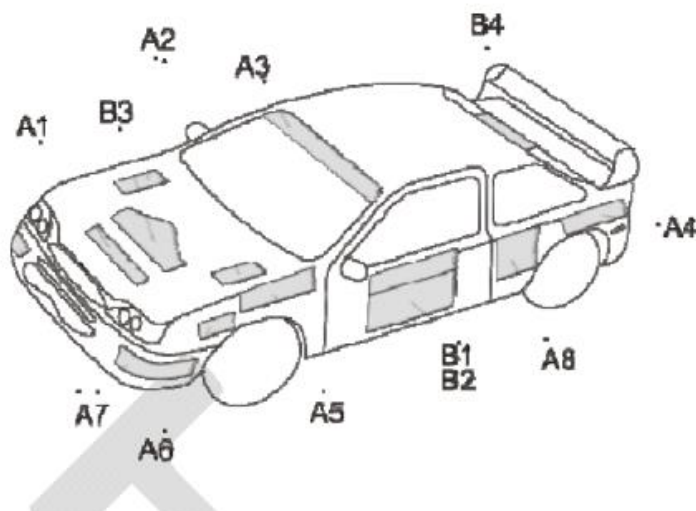

- A1 : TBA
A2 : Club/Sponsor
A3 : Sponsor
A4 : Sponsor
A5 : TBA
A6 : TBA
A7 : TBA
B1 ~ B3: Competition Number

DOCUMENTATION / INFORMATION REQUIRED FOR ISSUE OF PERMIT

- Risk Analysis document duly filled in and signed by the Organizer and COC
- Safety & Medical Document duly filled in & signed both by the CMO & COC.
- Associate Hospital close by, Distance by Road and Hospital confirmation letter for acceptance of any injured participant if required for treatment.
- Track Layout Drawing, Barricading Drawing, Pits Location drawing, Paddock, Assembly Area Drawing, Scrutiny Area Drawing, COC and Stewards Area drawing.
- List of permissions applied for and acknowledgement of application from the department.
- 3rd party event Insurance copy.
- Preferred date for track inspection by FMSCI delegate.
- Details of Timing Equipment being used.

Appendix IV.

To All Participants

We, the organisers of the....., follow the FMSCI Sustainability Guidelines, the FIA Guide to Sustainable Events and the FIM Environmental Code, to the best of our abilities, for the future of our sport, and to respect nature and the environment.

We ask you to

- use an environment mat or other approved system while servicing or refuelling in order to prevent spillage of oil and fuel into the ground.
 - use the oil collection containers available in the pits when disposing of used oil.
 - bring refillable water bottles.
 - use waste bins for all rubbish.
 - please leave your pits/ service area clean, so that there is no trace of your activity.
 - not leave used tyres or parts behind. Dispose of them correctly.
 - Download the FIA Smart Driving Challenge App to evaluate your CO2 emissions.
- Please help us make our sport clean and environmentally friendly.

**** END ****

Note: For further queries regarding the guidelines, please contact the Chairperson, Environment and Sustainability Commission, _____

NOTE-The supplementary regulation (SR) has been sent for FMSCI recognition.